

# Technical information

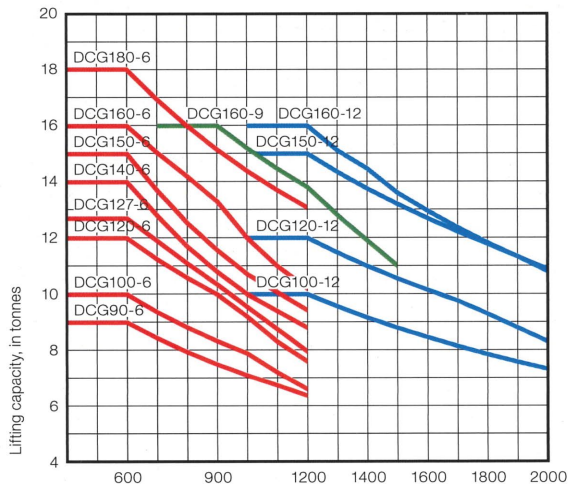

Load centre, mm

DCG90-6 to DCG180-6 models:  
Full lifting capacity up to 5000 mm lift height with duplex/duplex  
freelift/triplex masts and integrated sideshift/fork positioning carriage.

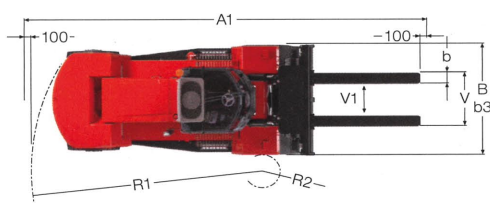
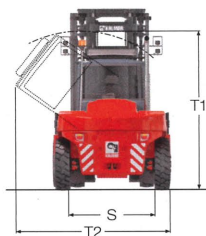
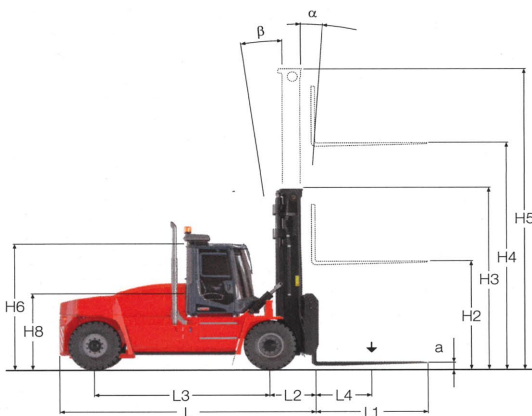

MAIN DATA		DCG 160-12	
Model designation	DCG 160-12		
Power source	Diesel		
Rated capacity / rated load	kg	16000	
Load center distance	mm	L4	1200
Load distance, center of drive axle to fork	mm	L2	1000
Wheelbase	mm	L3	3750
WEIGHTS			
Service weight	kg	22400	
Axle loading, unloaded front	kg	10500	
Axle loading, loaded front	kg	35800	
Axle loading, unloaded rear	kg	11900	
Axle loading, loaded rear	kg	2600	
WHEELS			
Type, front / rear			
Tyre size, front	inch		
Tyre size, rear	inch		
Number of wheels, front / rear (x = driven wheels)	4x / 2		
Track width, front / rear	mm	S	1855 / 1960
Tyre pressure	MPa	1,0	
DIMENSIONS			
Mast tilt, $\alpha$ = forward / $\beta$ = backward	°	$\alpha / \beta$	5 / 10
Height of mast lowered	mm	H3	4195
Lift height	mm	H4	5000
Height of mast extended	mm	H5	6565
Truck height – EGO / OHG cabin roof	mm	H6	2920
Seat height	mm	H8	1770
Height when tilting EGO cab / OHG	mm	T1	3395
Width when tilting EGO cab / OHG	mm	T2	3380
Truck length (to face of forks)	mm	L	5575
Truck width	mm	B	2540
Fork dimensions, width	mm	b	250
Fork dimensions, thickness	mm	a	100
Fork dimensions, length of fork arm	mm	l	2400
Fork carriage width	mm	b3	2500
Width over fork arms, minimum / maximum	mm	V	2360 / 700
Sideshift $\pm$ @ width over forks	mm	V1 / V	415 / 1530
Ground clearance, laden, below mast	mm	250	
Ground clearance, machine	mm	350	
Min. aisle width for 90° stacking with forks	mm	A1	8770
Turning radius	mm	R1	5175
Internal turning radius	mm	R2	600
OTHERS			
Operating pressure for hydraulics	MPa	18,0	
Hydraulic oil tank, capacity	l	220	
Fuel tank, capacity	l	170	
AdBlue tank, capacity	l	15	

Lift height H4	Mast height		Free lift H2
	H3 min	H5 max	
<b>DCG100-180**</b>			
5500	3463	7190	1833

+25 mm on H3 and H5 on the DCG140  
\*\*DCG150-180-6, DCG160-9, DCG100-160-12

TRIPLEX FFL, CW